

ENHANCE SUPERIOR CONNECTIVITY

with IRIDIUM Quadrifilar Helix Antenna (QFHA)



2J7B26JB-C177N-B16J "BIG MEDUSA Series" antenna

High Performance, superb RHCP, omnidirectional IRIDIUM antenna for satellite communication around the World
Lightweight, ground plane independent passive antenna with 2.7 dBi Peak Gain and Axial ratio below 3 dB
Heavy Duty IK09 and water resistant IP67 and IP69 for all marine and land environments
Various mounting options for screw and pole mount installation



1. Antenna and electrical specifications

Parameters	IRIDIUM QUADRIFILAR HELIX Antenna
Standards	Iridium
Bands (MHz)	1621
Frequency (MHz)	1616-1627
Return Loss (dB)	~ -17.6
VSWR	~ 1.3:1
Efficiency (%)	~ 86.4
Peak Gain (dBi)	~ 2.7
Impedance (Ohms)	50
Axial Ratio (dB)	3 dB max
Radiation Pattern	Omni-Directional
Polarization	RHCP
Connector Type	N-Female Standard

Antenna Measurement Conditions:

Free space

Measured in Certified CTIA 3D Anechoic Chamber

2. Mechanical and environmental specifications

Specifications	2J7B26JB-C177N-B16J
Mounting Type	Pole (for pole with max Ø 43mm) / Screw Mount (max 7mm surface thickness)
Dimensions (mm)	Ø 96 x H 200 - Pole Mount / Ø 96 x H 131 - Screw Mount
Rec. Tighten Torque (Nm)	6 Nm (for Screw Mount)
Radome	ASA
Radome color	White, Black
Antenna Base	ASA
Operating Temperature (C)	-40 to +85
Storage Temperature (C)	-40 to +85
Substance Compliance	RoHS
Certificates	IP67, IP69

3. Antenna parameters

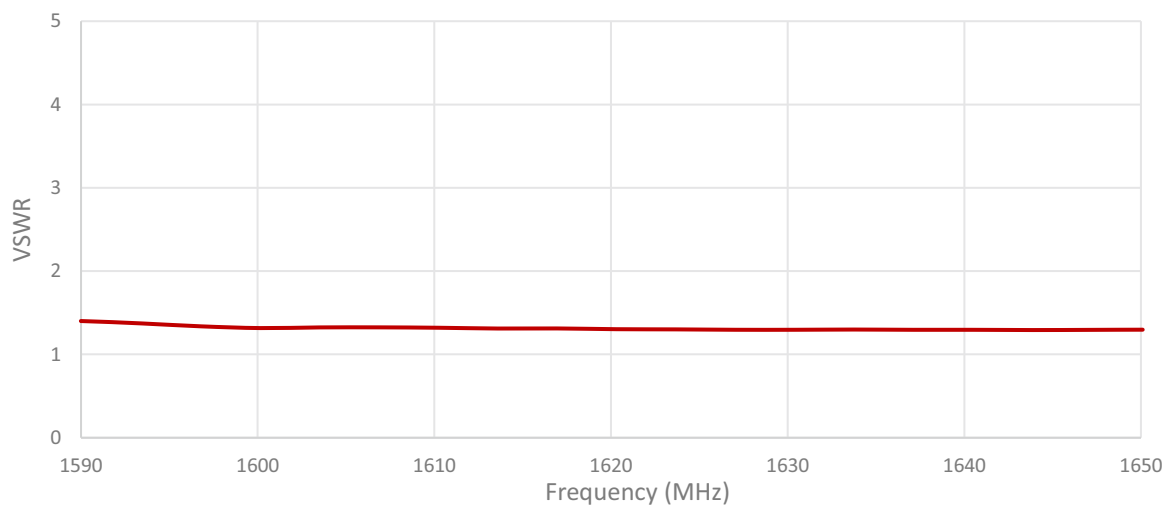
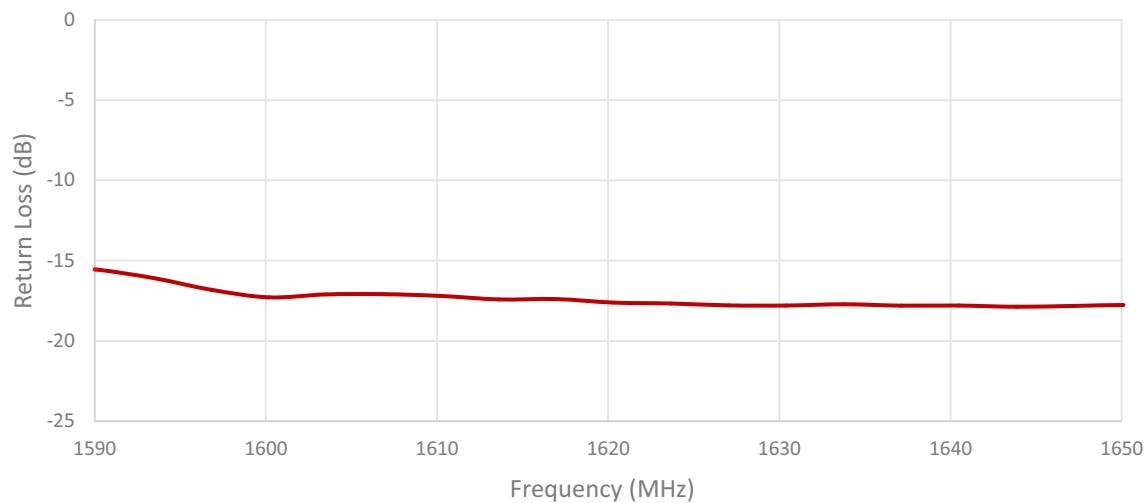

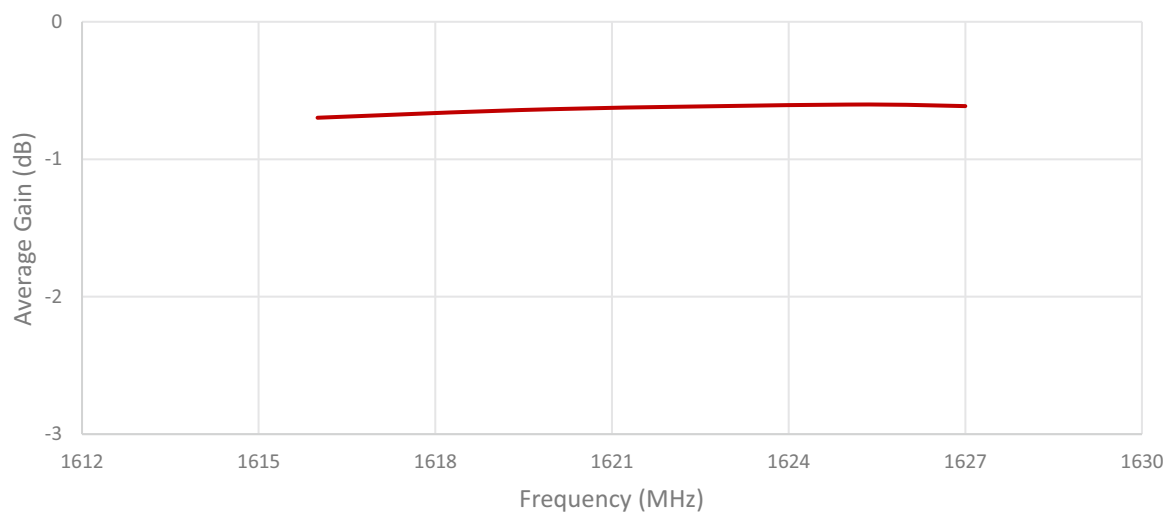
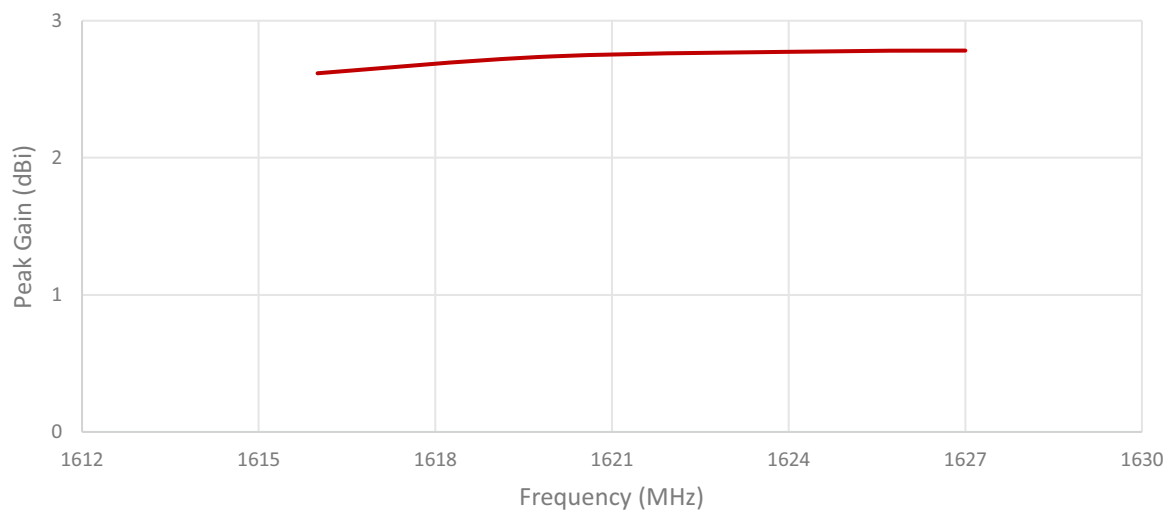
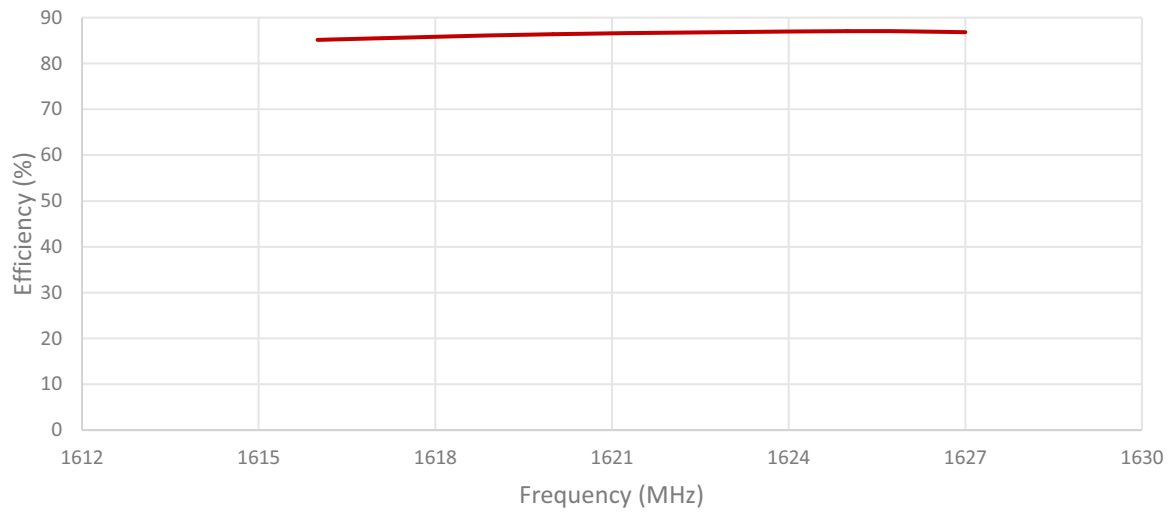

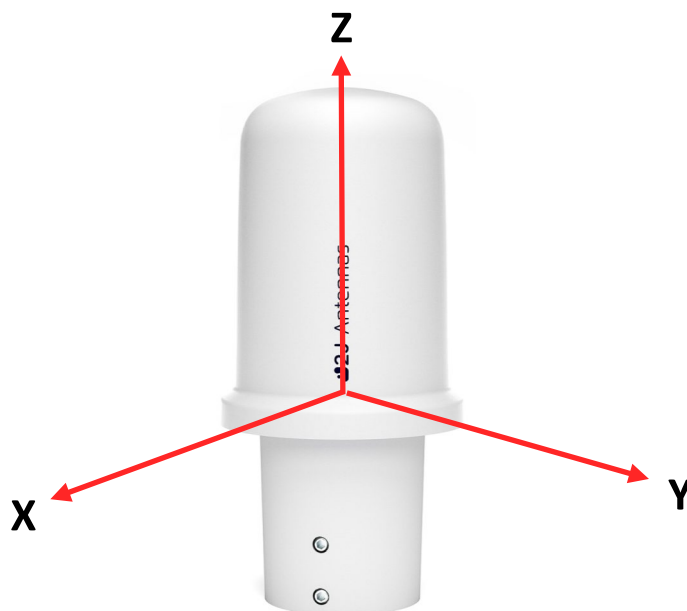

Radiation pattern reference

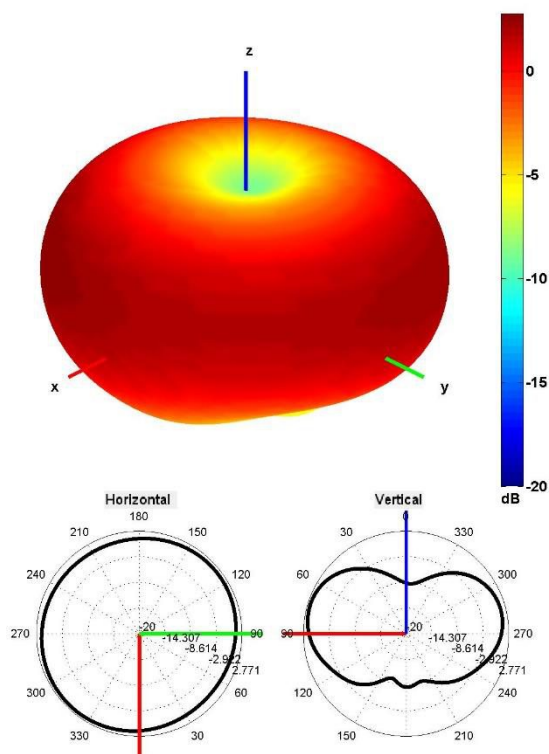

1621 MHz Radiation pattern

4. Antenna drawings

Pole Mount option using 2JB16J Bracket

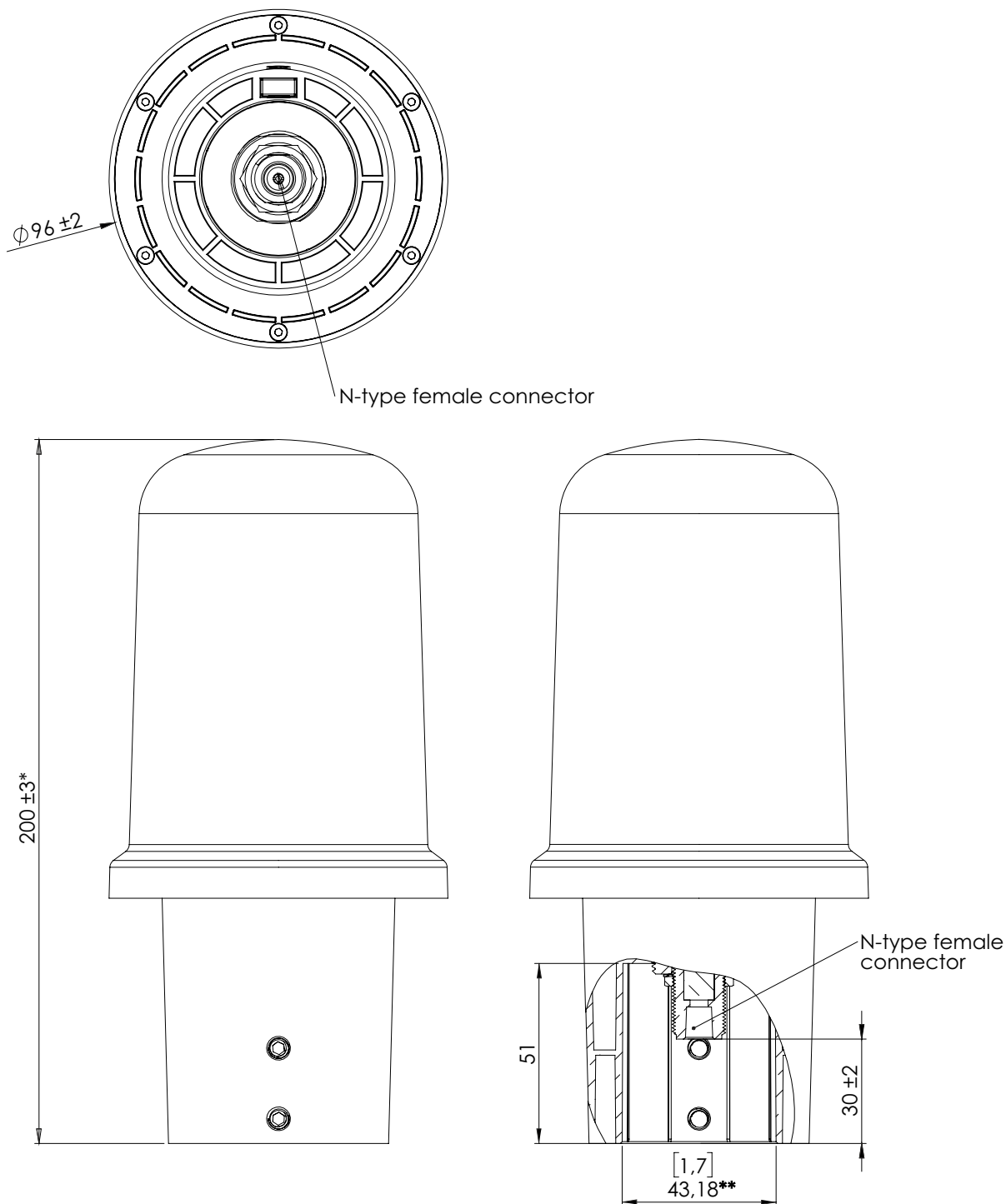

Note: Dimensions are in millimeters
***Dimensions are after mounting**
****Mounting for pole $\phi 43$ mm**

Screw Mount option

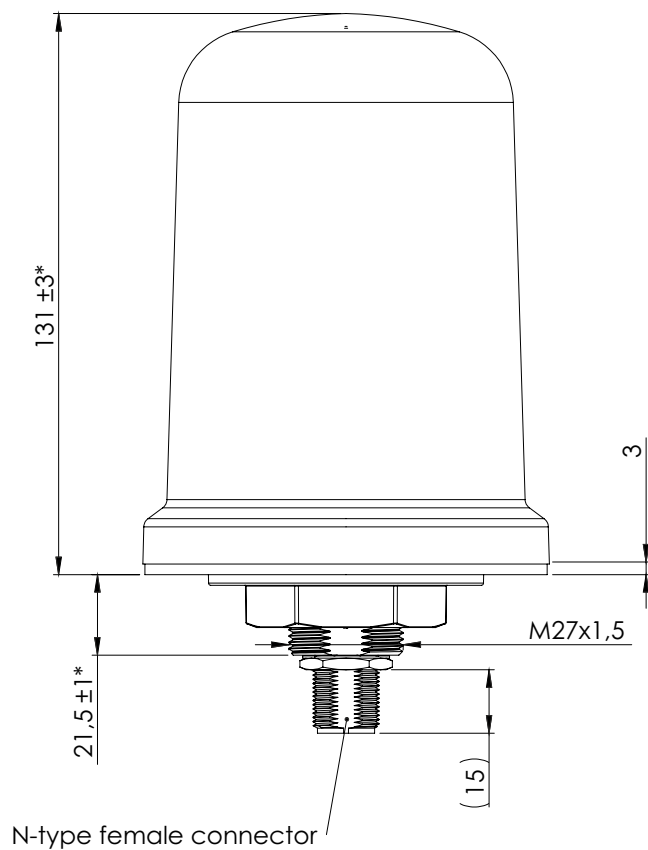
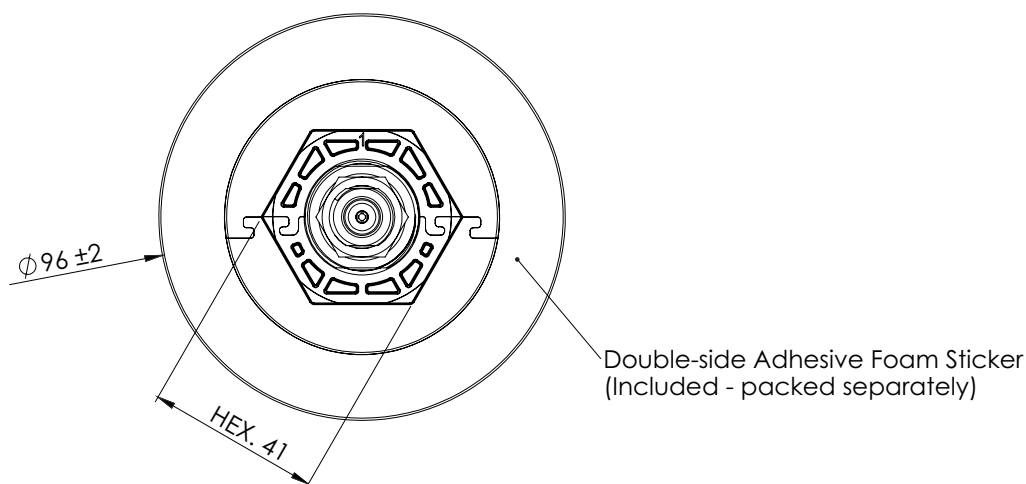

Mounting hole

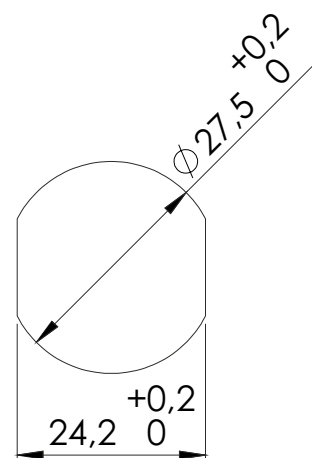

Note: Dimensions are in millimeters
***Dimensions are after mounting**
Max. mounting thickness 7mm
****Rec. Mounting Torque= 6 Nm**

5. Antenna Images

